

**PLAN**

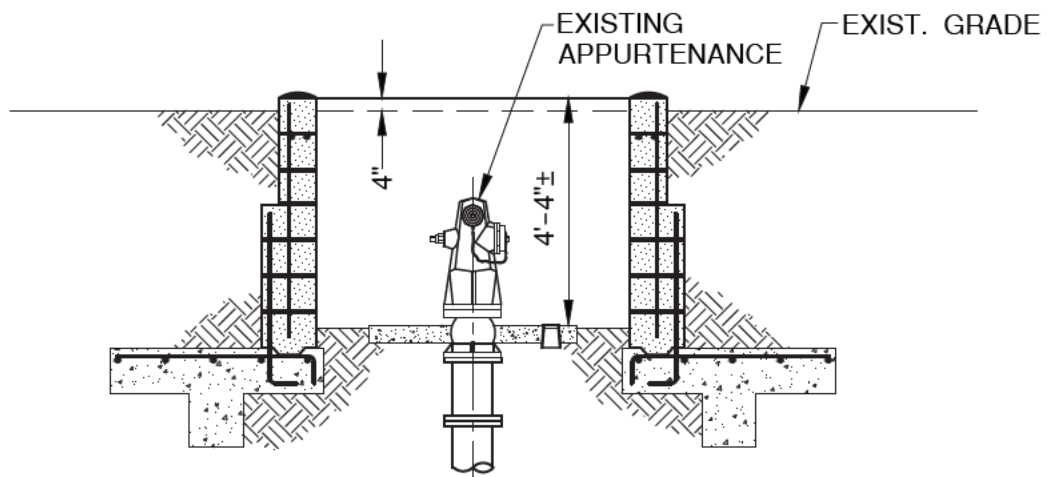

**SECTION A-A**

**NOTES:**

1. SEE SDRSD C-4, C-7 AND C-8 FOR ADDITIONAL DETAILS AND NOTES.
2. MASONRY BLOCK TYPE 1 SHALL CONFORM TO ASTM C90. SIZE SHALL BE 16" x 8" x 8" AND 16" x 12" x 8". UNITS SHALL BE SLUMP BLOCK. COLOR SHALL BE ADOBE.
3. FOR WALLS LESS THAN 30" IN HEIGHT, 16" x 8" x 8" STACKABLE BLOCKS MAY BE USED WITH DISTRICT ENGINEER APPROVAL.

APPROVED:

*Wally P. [Signature]* 5/16/19

District Engineer

Date

5/16/2019

Latest Revision Date



VALLEY CENTER MUNICIPAL WATER DISTRICT  
STANDARD DRAWING

**APPURTENANCE RETAINING WALL**

NOT TO SCALE

DWG. NUMBER

**W-33**