

**MARKER POST INSTALLATION**

**PLAN**

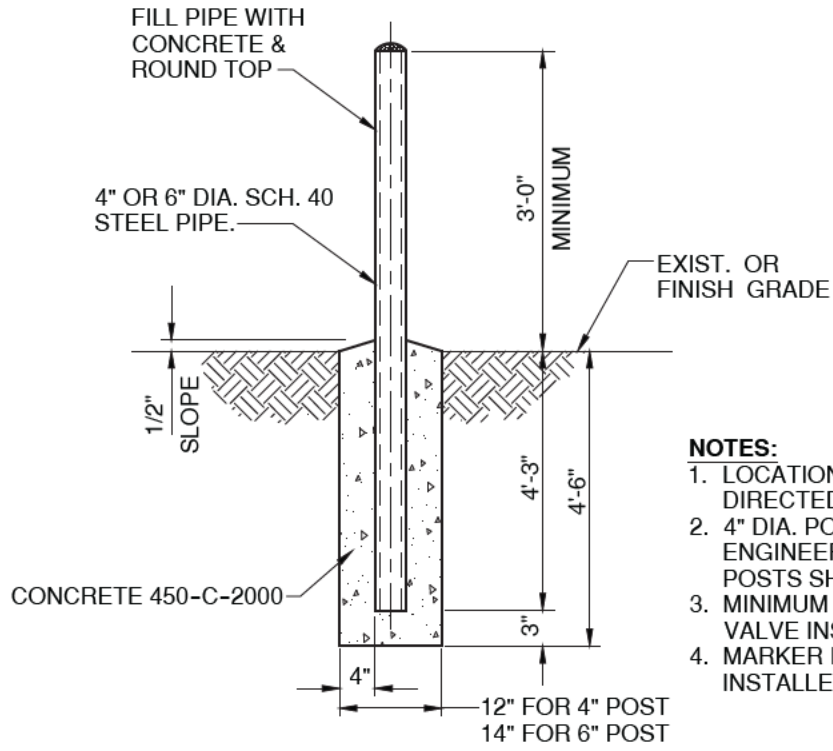

**NOTES:**

1. LOCATION SHALL BE AS SHOWN ON PLAN VIEW OR AS DIRECTED IN THE FIELD BY DISTRICT ENGINEER.
2. 4" DIA. POSTS SHALL BE APPROVED BY DISTRICT ENGINEER. FOR SPEED GREATER THAN 30 MPH, 6" DIA. POSTS SHALL BE USED.
3. MINIMUM OF TWO MARKER POSTS REQUIRED FOR EACH VALVE INSTALLED.
4. MARKER POSTS AND GUARD POSTS SHALL NOT BE INSTALLED WITHIN COUNTY RIGHT OF WAY.

**GUARD POST INSTALLATION**

APPROVED:	
<i>Wally P. [Signature]</i>	5/16/19
District Engineer	Date
5/16/2019	
Latest Revision Date	

 <p>VALLEY CENTER MUNICIPAL WATER DISTRICT STANDARD DRAWING</p>
<p><b>GUARD &amp; MARKER POST INSTALLATION</b></p>

NOT TO SCALE
DWG. NUMBER
<b>W-31</b>