

4' PIECE INTO END CAP

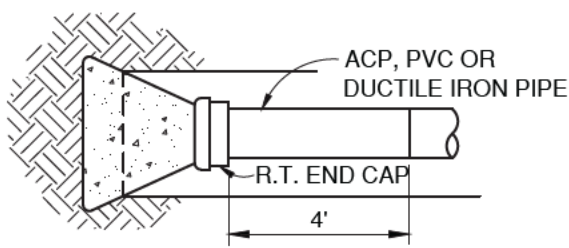

12" x 12" x 1/2" STL. PLATE  
TO 3" x 12" STD. STL. GALV. PIPE  
BLIND FLG. WELDED TO PIPE

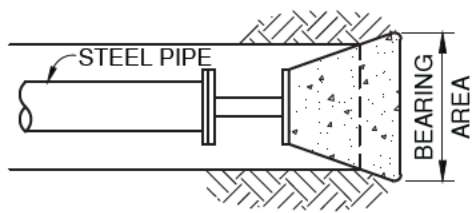

A.C. PIPE END DETAIL  
PLAN VIEW

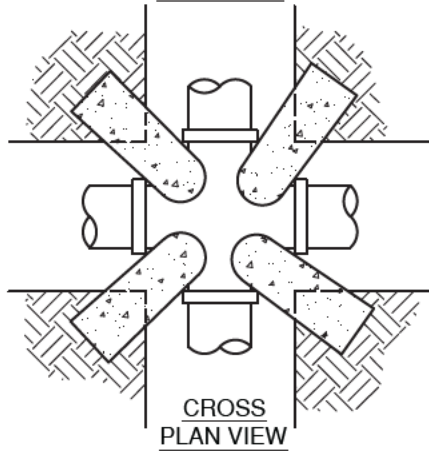

STEEL PIPE END DETAIL  
PLAN VIEW

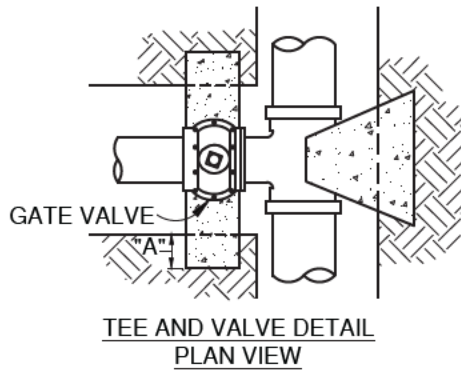
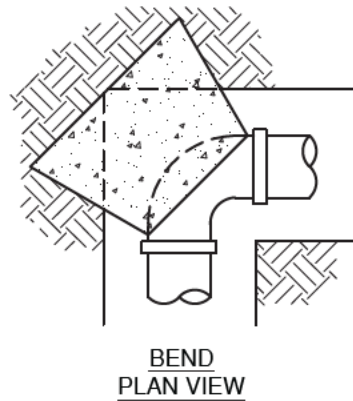

TEE AND VALVE DETAIL  
PLAN VIEW

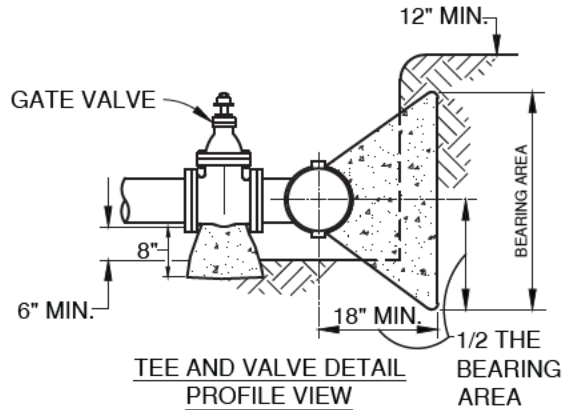

TEE AND VALVE DETAIL  
PROFILE VIEW

MINIMUM BEARING AREAS IN SQ.FT. FOR CLASS 150 PIPE

MAIN SIZE	TEES. P.E.	90° BEND	45° BEND	22-1/2° BEND
6"	6	8	5	3
8"	10	14	8	4
10"	17	23	13	7
12"	23	33	18	9
14"	31	44	24	12
16"	40	57	31	16
18"	52	75	40	21

FOR CLASS 165 MULTIPLY BY 1.3  
FOR CLASS 235 MULTIPLY BY 1.7  
FOR CLASS 305 MULTIPLY BY 2.0

**NOTE:**  
SEE DWG NO. W-21 FOR VALVE SUPPORT DETAIL

<p>APPROVED:</p>  <p>District Engineer Date</p> <p>5/16/2019 Latest Revision Date</p>	 <p>VALLEY CENTER MUNICIPAL WATER DISTRICT STANDARD DRAWING</p>	<p>NOT TO SCALE</p> <p>DWG. NUMBER</p> <p><b>W-20</b></p>
<p><b>CONCRETE THRUST BLOCKS</b></p>		