

SUBMIT V.C.P. COLLAR TEE SADDLE FOR APPROVAL, EPOXIED IN PLACE PRIOR TO ENCASING.

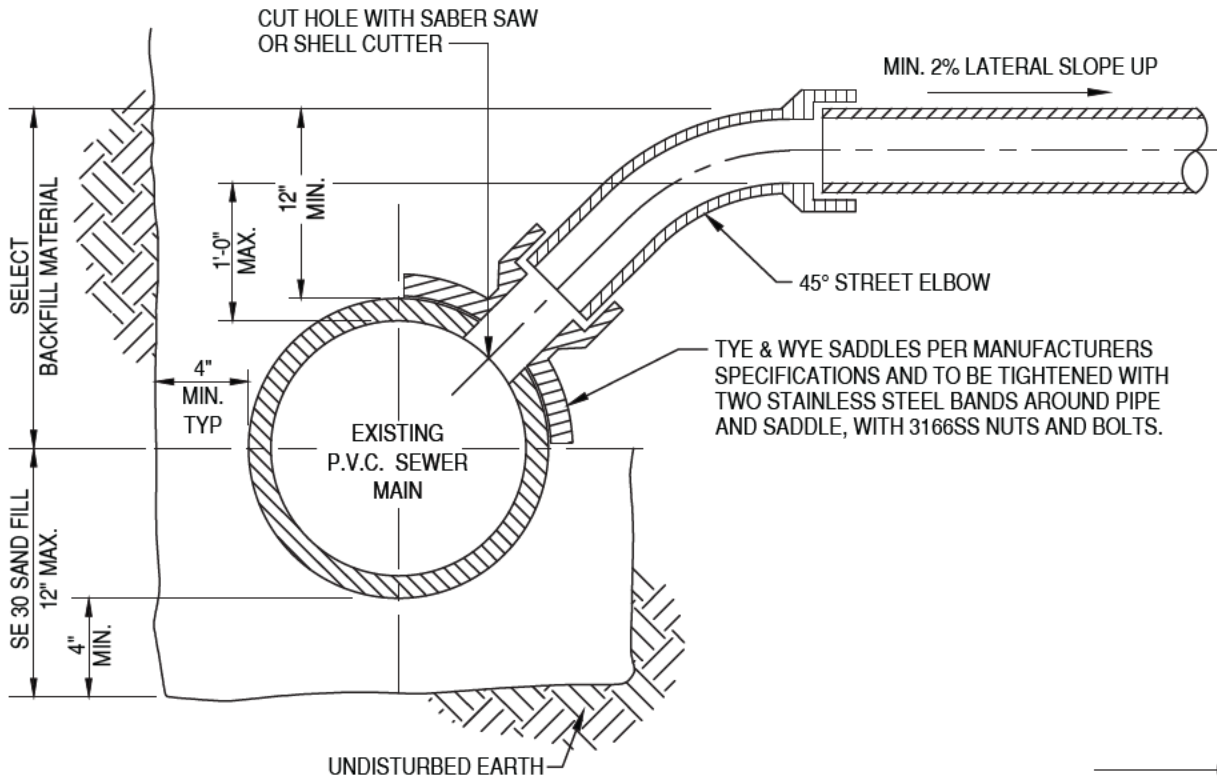
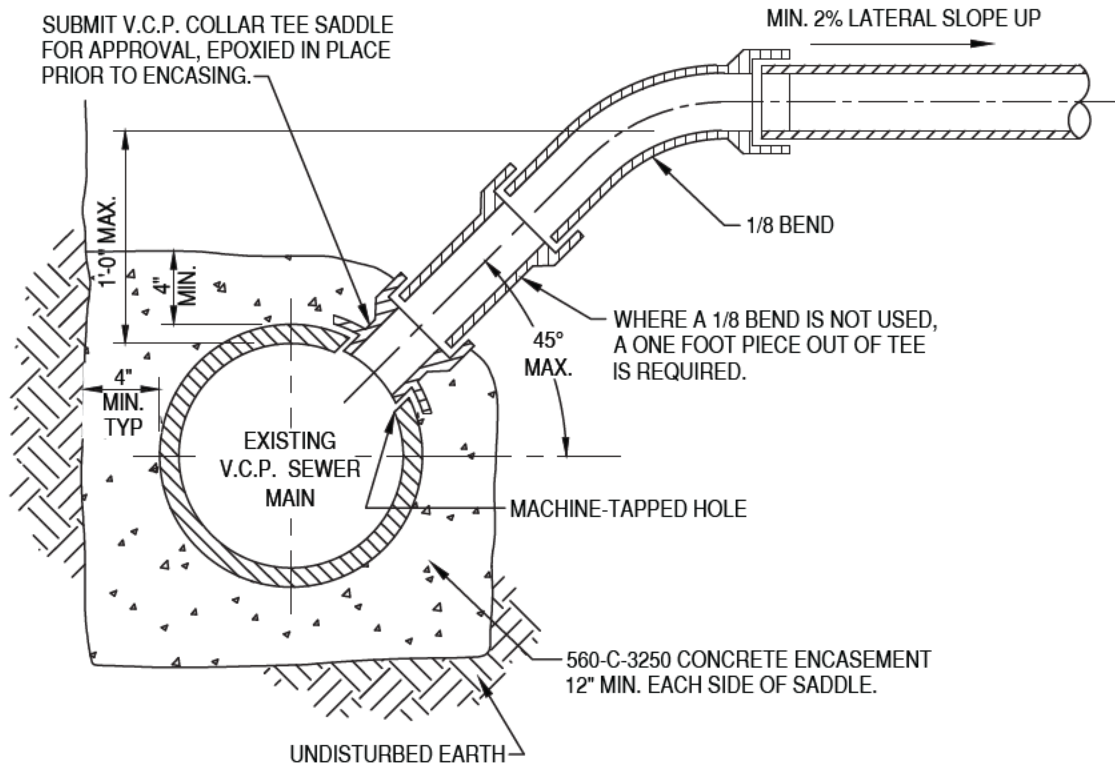

— (S) —  
LEGEND ON PLAN

APPROVED:  
*Wally Paul* 5/16/19  
District Engineer Date  
5/16/2019  
Latest Revision Date

VALLEY CENTER MUNICIPAL WATER DISTRICT  
STANDARD DRAWING  
**SEWER LATERAL CUT IN**

NOT TO SCALE  
DWG. NUMBER  
**S-13**